

F. T. Grant,

Gage Lathe

N^o 37,960.

Patented Mar. 24, 1863.

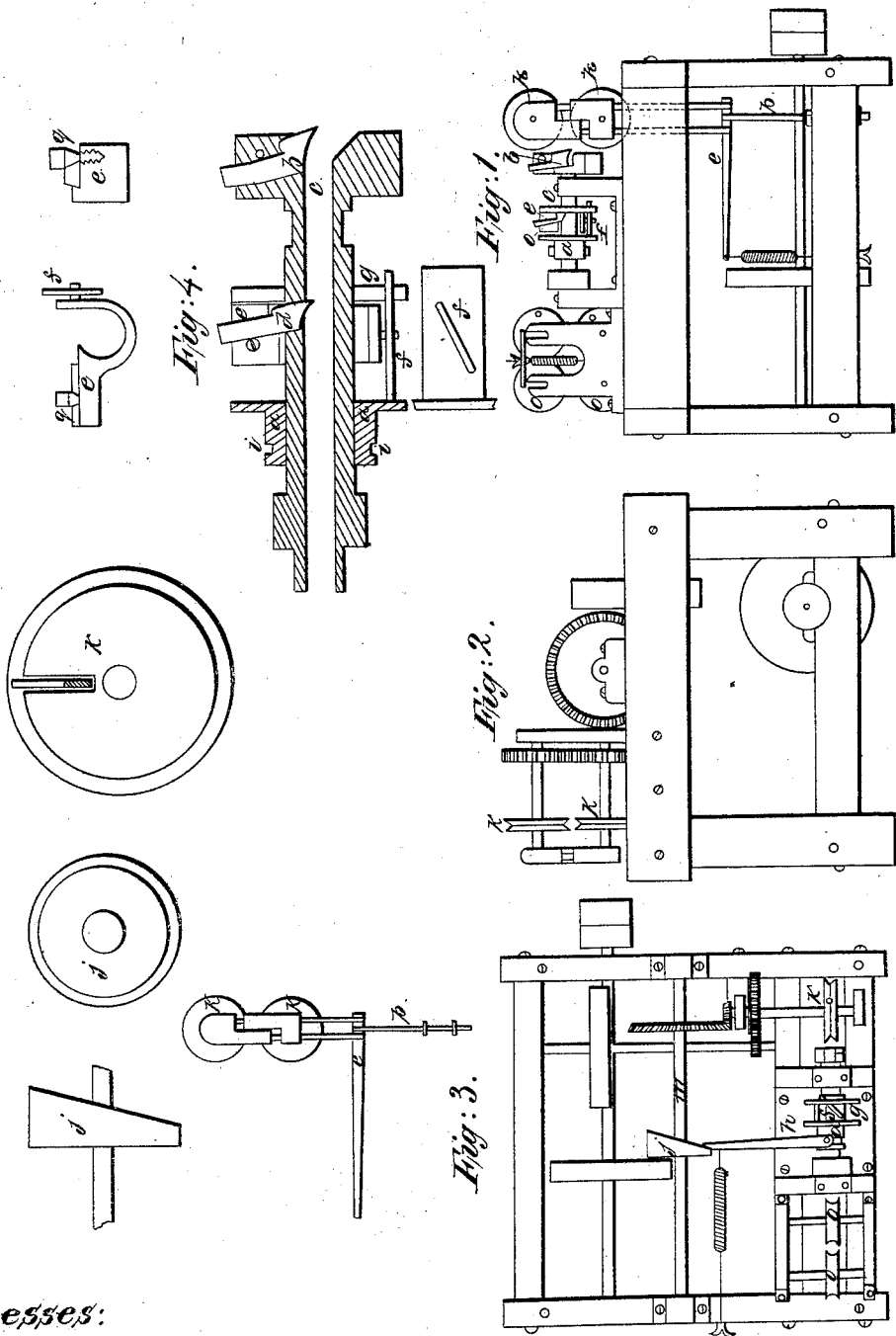

Witnesses:

Samuel T. Combs
Wm. H. Libby

Inventor:

Frederic T. Grant

UNITED STATES PATENT OFFICE.

FREDERIC T. GRANT, OF AUGUSTA, MAINE.

LATHE FOR TURNING IRREGULAR FORMS.

Specification forming part of Letters Patent No. 37,960, dated March 24, 1863.

To all whom it may concern:

Be it known that I, FREDERIC T. GRANT, of Augusta, in the county of Kenebec, in the State of Maine, have invented a new and Improved Machine or Lathe for Turning Irregular Sizes; and I do hereby declare that the following is a full, clear, and exact description of the construction and operation of the same, reference being had to the annexed drawings, making a part of this specification, in which—

Figure 1 is a perspective view. Fig. 2 is an end, Fig. 3 is a top, Fig. 4 is a sectional, view of mandrel, with sliding collar *a* and knives *d b*.

The nature of my invention consists in providing a hollow mandrel with a cutter or knife that shall expand or contract so as to turn a stick of any irregular size, requiring the knife traveling around the stick, while the stick is being moved or fed through the hollow mandrel endwise, by a pair of rolls of peculiar construction and operation to hold the center of the stick, and feed it to the center of the hollow mandrel at all times.

To enable others skilled in the art to make and use my invention, I will proceed to describe its construction and operation.

I construct the hollow mandrel about the same as is generally used for turning sticks all of one size, with a gouge, *b*, attached to the front end, to round the stick all of one size, as it passes into the hollow mandrel *c*, and passes along to the expanding cutter *d*, which is attached by a joint-bolt, *e e*, to the flange *g*, made fast to the mandrel *c*. The other end of rest *e* is provided with a pin or bolt, *i i*, that projects into the inclined slot cut in the plate *f*. One end of said plate slips loosely through the flange *g*, the other end fastened to the sliding collar *a*, and moves back and forward parallel with the mandrel *c*, to give the required dip of the knife *d*. Said sliding collar *a* slips on a pline or key bedded into the mandrel. All of these part revolve together. Said sliding collar *a* is provided with a groove, *i*, turned around the outside, for the purpose of attaching power to move

sliding collar *a* lengthwise of the mandrel *c*, that shall not turn with collar *a*, and is moved by the lever *h*, or its equivalent, the fulcrum of the lever *h* being at any desired point, the other end of lever resting against the side cam, *j* on shaft *m*, and held against it by the spiral spring *r*, or any convenient way, said cam *j*, or into its equivalent, operating the sliding collar.

The object of the V-shaped tools *k k* is to hold the square stick to be turned up cornerwise, so as to find the center of stick one way, and the object of double-acting lever *l* is to raise one tool as fast as the other tool lowers, thereby finding the center of stick the other way. Said feed-tools are made of a suitable size, so they shall turn a given number of times to the length of the stick to be turned. Said feed-tools *k k* are geared to the cam-shaft *m*, so that the feed-tools shall feed two sticks through while the cam is turning once, thereby making the two ends of sticks of a size together, thereby giving a steady motion to the sliding collar *a* and what it is attached to.

The object of the elastic pin *n* in the feed-tool *k* is for a gage to put the end of stick against it, to have it pass into the mandrel at the right time, and if the tool turns more than once to the length of stick the pin is pressed in by the stick.

The object of the grooved tools *o o o o* is to hold the stick from turning as it passes from the mandrel, and guide it straight out.

The knives *d* are fastened to the rests *e* by one side of the shank of knife being beveled, and a similar place, *s*, cut in the rest *e*, to fit it, while the other side is held up by a cone-shaped bolt, *g*.

The object of the adjustable screws at the bottom of rod *p* is to adjust the feed-tools *k k*.

What I claim as my invention, and desire to secure by Letters Patent, is—

1. The sliding collar *a*, or its equivalent, operated by cam, *j*, or its equivalent, to operate the knife *d* in any way or manner, that it may be attached to sliding collar *a*, as is specified and set forth.

2. I do not claim this form of cam, nor any other form of cam to operate the collar; but I claim the whole principle of the sliding collar *a*, in any manner that it may be moved as specified, and in any way or manner that it may be attached to the expanding knife *d*, as is set forth, and for the purpose specified.

3. The V-shaped feed-tools *k k*, when com-

bined with the double-acting lever *e*, as set forth, and for the purpose specified.

4. The mode of fastening the knives *d b*, as set forth and specified.

FREDERIC T. GRANT.

Witnesses:

SAMUEL TITCOMB,
WM. H. LIBBY.